

## BRECOflex Clamps – Solutions for Timing Belt Linear Drives

All timing belt linear drives require a clamp to transfer the belt motion to linear shuttle travel. BRECOflex clamps and tensioning clamps for metric and English pitch belts ensure a solid attachment for utilization of full belt strength. Custom clamps are available in various materials and coatings. One or more of the following three clamp types are recommended depending on drive layout.

1) Standard Clamp

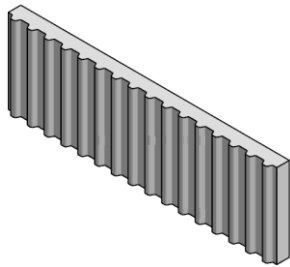

2) Half Clamp

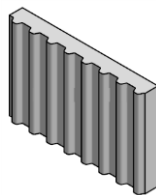

3) Tensioning Clamp

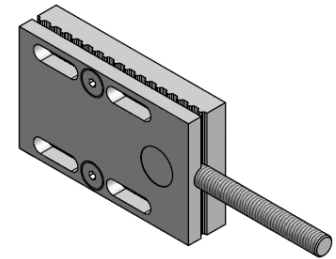

Application Examples for 3 clamp types:

1) Standard Clamp – used for connecting both belt ends together at the carriage

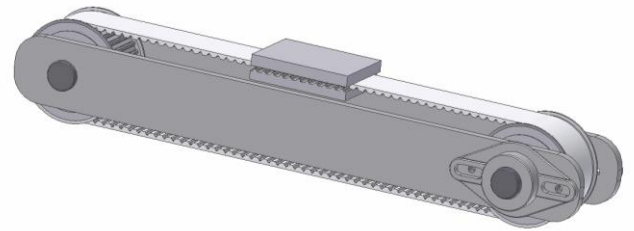

2) Half Clamp – used for connecting each belt end to the carriage or machine frame

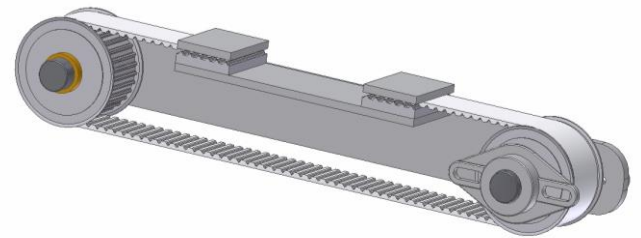

3) Tensioning Clamp – used like a half clamp, but also to adjust tension in the system

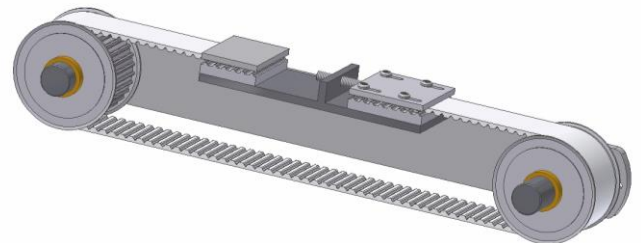

## Standard Clamps (metric pitches) – Used for connecting both belt ends

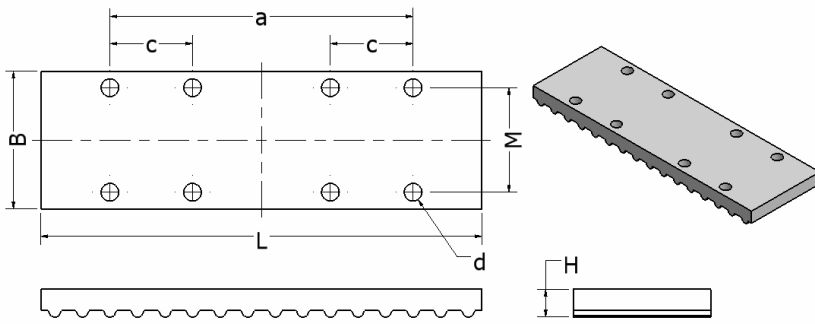

Clamp part description:

B x L (belt pitch) Type (O or B)  
 Type O = clamp with no holes  
 Type B = clamp with holes (shown)

Note:

- Standard material is AL 6061
- 5 teeth minimum engagement recommended at each belt end
- (\*) 6 mounting holes for T2.5 clamps

Standard Clamp Dimensions – T Series Metric

Belt Pitch	Belt Width b(mm)	Part Description	B (mm)	L (mm)	d (mm)	m (mm)	a (mm)	c (mm)	H (mm)
T2.5	10	30 x 50 T2.5 Clamp Type (O or B*)	30	50	5.5	20	30	15	6
	20	40 x 60 T2.5 Clamp Type (O or B*)	40	60		30			
T5	25	50 x 120 T5 Clamp Type (O or B)	50	120	5.5	38	80	20	10
	32	60 x 120 T5 Clamp Type (O or B)	60			46			
	50	75 x 120 T5 Clamp Type (O or B)	75			62			
	75	110 x 120 T5 Clamp Type (O or B)	110			94			
	100	140 x 120 T5 Clamp Type (O or B)	140			124			
T10	25	50 x 160 T10 Clamp Type (O or B)	50	160	6.5	38	110	30	10
	32	60 x 160 T10 Clamp Type (O or B)	60			46			
	50	75 x 160 T10 Clamp Type (O or B)	75			62			
	75	110 x 160 T10 Clamp Type (O or B)	110			94			
	100	140 x 160 T10 Clamp Type (O or B)	140			124			
	150	190 x 160 T10 Clamp Type (O or B)	190			174			
T20	25	50 x 200 T20 Clamp Type (O or B)	50	200	6.5	38	160	60	20
	32	60 x 200 T20 Clamp Type (O or B)	60			46			
	50	75 x 200 T20 Clamp Type (O or B)	75			62			
	75	110 x 200 T20 Clamp Type (O or B)	110			94			
	100	140 x 200 T20 Clamp Type (O or B)	140			124			
	150	190 x 200 T20 Clamp Type (O or B)	190			166			

**Standard Clamps (metric pitches) – Used for connecting both belt ends**

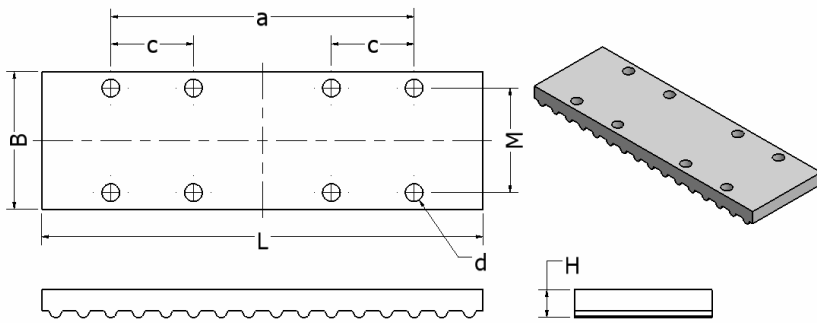

Clamp part description:

B x L (belt pitch) Type (O or B)  
 Type O = clamp with no holes  
 Type B = clamp with holes (shown)

Notes:

- Standard material is AL 6061
- 5 teeth minimum engagement recommended at each belt end

Standard Clamp Dimensions – AT Series Metric									
Belt Pitch	Belt Width b(mm)	Part Description	B(mm)	L (mm)	d (mm)	m (mm)	a (mm)	c (mm)	H (mm)
AT3	10	30 x 75 AT3 Clamp Type (O or B)	30	75	5.5	20	50	12.5	8
	20	50 x 75 AT3 Clamp Type (O or B)	50			30			
	25	60 x 75 AT3 Clamp Type (O or B)	60			38			
AT5	25	50 x 120 AT5 Clamp Type (O or B)	50	120	5.5	38	80	20	10
	32	60 x 120 AT5 Clamp Type (O or B)	60			46			
	50	75 x 120 AT5 Clamp Type (O or B)	75			62			
	75	110 x 120 AT5 Clamp Type (O or B)	110			94			
	100	140 x 120 AT5 Clamp Type (O or B)	140			124			
AT10 BAT10 BATK10	25	50 x 160 [Pitch] Clamp Type (O or B)	50	160	6.5	38	110	30	10
	32	60 x 160 [Pitch] Clamp Type (O or B)	60			46			
	50	75 x 160 [Pitch] Clamp Type (O or B)	75			62			
	75	110 x 160 [Pitch] Clamp Type (O or B)	110			94			
	100	140 x 160 [Pitch] Clamp Type (O or B)	140			124			
	150	190 x 160 [Pitch] Clamp Type (O or B)	190			174			
ATS15 BAT15 BATK15	25	50 x 180 [Pitch] Clamp Type (O or B)	50	180	9	38	140	50	20
	32	60 x 180 [Pitch] Clamp Type (O or B)	60			46			
	50	75 x 180 [Pitch] Clamp Type (O or B)	75			62			
	75	110 x 180 [Pitch] Clamp Type (O or B)	110			94			
AT20	25	50 x 200 AT20 Clamp Type (O or B)	50	200	9	38	160	60	20
	32	60 x 200 AT20 Clamp Type (O or B)	60			46			
	50	75 x 200 AT20 Clamp Type (O or B)	75			62			
	75	110 x 200 AT20 Clamp Type (O or B)	110			94			
	100	140 x 200 AT20 Clamp Type (O or B)	140			124			
	150	190 x 200 AT20 Clamp Type (O or B)	190			166			

## Standard Clamps (imperial pitches) – Used for connecting both belt ends

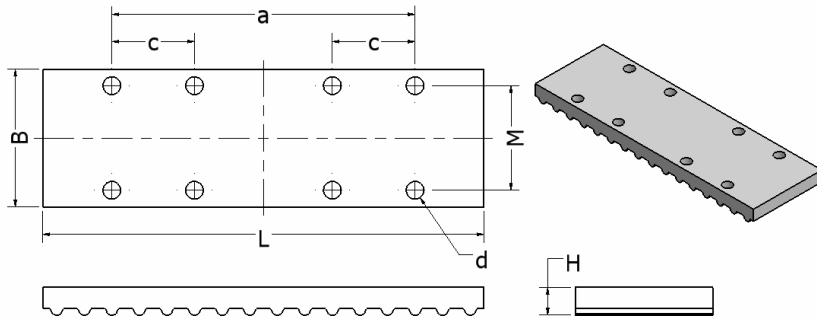

Clamp part description:

B x L (belt pitch) Type (O or B)  
 Type O = clamp with no holes  
 Type B = clamp with holes (shown)

Notes:

-Standard material is AL 6061  
 -5 teeth minimum engagement recommended at each belt end

Standard Clamp Dimensions – Imperial Series									
Belt Pitch	Belt Width b(mm)	Part Description	B (mm)	L (mm)	d (mm)	m (mm)	a (mm)	c (mm)	H (mm)
T1/5" (XL)	25.4	50 x 120 T1/5" Clamp Type (O or B)	50	120	5.5	38	80	20	10
	38.1*	60 x 120 T1/5" Clamp Type (O or B)	60			46			
	50.8*	75 x 120 T1/5" Clamp Type (O or B)	75			62			
	76.2*	110 x 120 T1/5" Clamp Type (O or B)	110			94			
T3/8" (L)	25.4	50 x 160 T3/8" Clamp Type (O or B)	50	160	6.5	38	110	30	10
	38.1	60 x 160 T3/8" Clamp Type (O or B)	60			46			
	50.8	75 x 160 T3/8" Clamp Type (O or B)	75			62			
	76.2	110 x 160 T3/8" Clamp Type (O or B)	110			94			
T1/2" (H)	25.4	50 x 160 T1/2" Clamp Type (O or B)	50	160	6.5	38	110	30	10
	38.1	60 x 160 T1/2" Clamp Type (O or B)	60			46			
	50.8	75 x 160 T1/2" Clamp Type (O or B)	75			62			
	76.2	110 x 160 T1/2" Clamp Type (O or B)	110			94			
	101.6	140 x 160 T1/2" Clamp Type (O or B)	140			124			
T7/8" (XH)	25.4	50 x 200 T7/8" Clamp Type (O or B)	50	200	6.5	38	160	60	20
	38.1	60 x 200 T7/8" Clamp Type (O or B)	60			46			
	50.8	75 x 200 T7/8" Clamp Type (O or B)	75			62			
	76.2	110 x 200 T7/8" Clamp Type (O or B)	110			94			
	101.6	140 x 200 T7/8" Clamp Type (O or B)	140			124			

(\* ) Belt widths only available in truly endless construction.

## Half Clamps (metric pitches) - Used for connecting one belt end

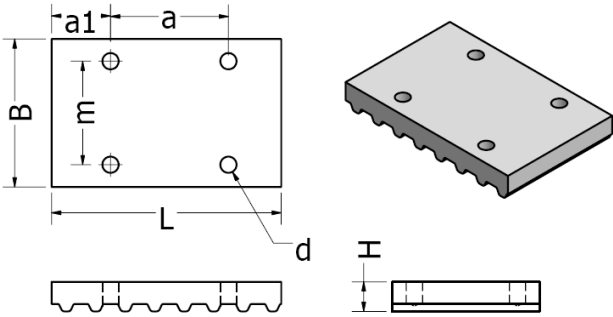

Clamp part description:

B x L (belt pitch) Type (O or B)  
 Type O = clamp with no holes  
 Type B = clamp with holes (shown)

Notes:

-Standard material is AL 6061  
 -5 teeth minimum engagement recommended at each belt end

Short Clamp Dimensions – T and HTD Metric

Belt Pitch	Belt Width b(mm)	Part Description	B (mm)	L (mm)	d (mm)	m (mm)	a (mm)	a1 (mm)	H (mm)
T5	25	50 x 58 T5 Clamp Type (O or B)	50	58	5.5	35	30	15	10
	32	60 x 58 T5 Clamp Type (O or B)	60			42			
	50	75 x 58 T5 Clamp Type (O or B)	75			60			
	75	110 x 58 T5 Clamp Type (O or B)	110			90			
T10	25	50 x 78 T10 Clamp Type (O or B)	50	78	6.5	35	40	20	10
	32	60 x 78 T10 Clamp Type (O or B)	60			42			
	50	75 x 78 T10 Clamp Type (O or B)	75			60			
	75	110 x 78 T10 Clamp Type (O or B)	110			90			
T20	25	50 x 98 T20 Clamp Type (O or B)	50	78	9	35	60	20	20
	32	60 x 98 T20 Clamp Type (O or B)	60			42			
	50	75 x 98 T20 Clamp Type (O or B)	75			60			
	75	110 x 98 T20 Clamp Type (O or B)	110			90			
HTD 5M	10	28 x 41.8 5M Clamp Type (O or B)	28	41.8	5.5	16	25	-	8
	15	34 x 41.8 5M Clamp Type (O or B)	32			22			
	25	75 x 41.8 5M Clamp Type (O or B)	50			32			
HTD 8M	20	45 x 66 8M Clamp Type (O or B)	45	66	9	29	40	-	15
	30	55 x 66 8M Clamp Type (O or B)	60			39			
	50	75 x 66 8M Clamp Type (O or B)	75			59			
	85	110 x 66 8M Clamp Type (O or B)	110			94			
HTD14M	40	71 x 116 14M Clamp Type (O or B)	71	116	11	51	70	-	22
	55	86 x 116 14M Clamp Type (O or B)	86			66			
	85	116 x 116 14M Clamp Type (O or B)	116			96			

## Half Clamps (metric pitches) - Used for connecting one belt end

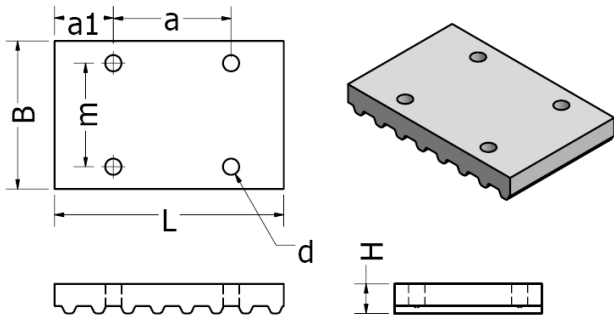

Clamp part description:

B x L (belt pitch) Type (O or B)  
 Type O = clamp with no holes  
 Type B = clamp with holes (shown)



Notes:



-Standard material is AL 6061  
 -5 teeth minimum engagement recommended at each belt end

Short Clamp Dimensions – AT Series Metric									
Belt Pitch	Belt Width b(mm)	Part Description	B (mm)	L (mm)	d (mm)	m (mm)	a (mm)	a1 (mm)	H (mm)
AT5	25	50 x 58 AT5 Clamp Type (O or B)	50	58	5.5	35	30	15	10
	32	60 x 58 AT5 Clamp Type (O or B)	60			42			
	50	75 x 58 AT5 Clamp Type (O or B)	75			60			
	75	110 x 58 AT5 Clamp Type (O or B)	110			90			
AT10 BAT10 BATK10	25	50 x 78 [Pitch] Clamp Type (O or B)	50	78	6.5	35	40	20	10
	32	60 x 78 [Pitch] Clamp Type (O or B)	60			42			
	50	75 x 78 [Pitch] Clamp Type (O or B)	75			60			
	75	110 x 78 [Pitch] Clamp Type (O or B)	110			90			
ATS15 BAT15 BATK15	25	50 x 88 [Pitch] Clamp Type (O or B)	50	88	9	35	50	20	20
	32	60 x 88 [Pitch] Clamp Type (O or B)	60			42			
	50	75 x 88 [Pitch] Clamp Type (O or B)	75			60			
	75	110 x 88 [Pitch] Clamp Type (O or B)	110			90			
AT20	25	50 x 98 AT20 Clamp Type (O or B)	50	98	9	35	60	20	20
	32	60 x 98 AT20 Clamp Type (O or B)	60			42			
	50	75 x 98 AT20 Clamp Type (O or B)	75			60			
	75	110 x 98 AT20 Clamp Type (O or B)	110			90			

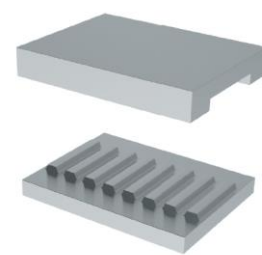
**Tensioning Clamps – Used to connect to one belt end and apply tension to the belt**

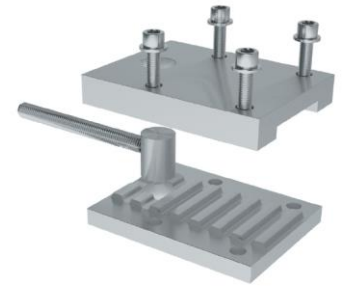
Tensioning Clamp Options						
Belt Pitch	Belt Width (mm)					
	25	32	50	75	100	150
T5	Type A-[1,2 or 3]	Type A-[1,2 or 3]	Type A-[1,2 or 3]	-	-	-
T10	Type A-[1,2 or 3]	Type A-[1,2 or 3]	Type A-[1,2 or 3]	-	-	-
T20	-	-	Type B-1	Type B-2	Type B-2	Type C
AT5	Type A-[1,2 or 3]	Type A-[1,2 or 3]	Type A-[1,2 or 3]	-	-	-
AT10	Type A-[1,2 or 3]	Type A-[1,2 or 3]	Type A-[1,2 or 3]	Type B-2	Type B-2	Type C
AT20	-	-	Type B-1	Type B-2	Type B-2	Type C
ATL10	Type A-[1,2 or 3]	Type A-[1,2 or 3]	Type B-1	Type B-2	Type B-2	-
ATL20	-	-	Type B-1	Type B-2	Type B-2	-
BATK10	-	Type A-[1,2 or 3]	Type A-[1,2 or 3]	Type B-2	Type B-2	-
BATK15	-	-	Type B-1	Type B-2	Type B-2	-
ATS15	-	-	Type B-1	Type B-2	Type B-2	Type C

Clamp Plate with Top Plate	Standard Tensioning Clamp	Standard Tensioning Clamp
		
Type A-1 without tensing rod and holes – Pg. 8	Type A-2 with tensing rod and slotted holes – Pg. 9	Type A-3 with tensing rod and threaded holes – Pg. 10

Interchangeable Tensioner Clamp	Interchangeable Tensioner Clamp	High Load Tensioning Clamp
		
Type B-1 with tensing rod and slotted holes – Pg. 11	Type B-2 with tensing rod and slotted holes – Pg. 12	Type C with tensing rod and slotted holes – Pg. 13

## Clamp Assembly Type A-1

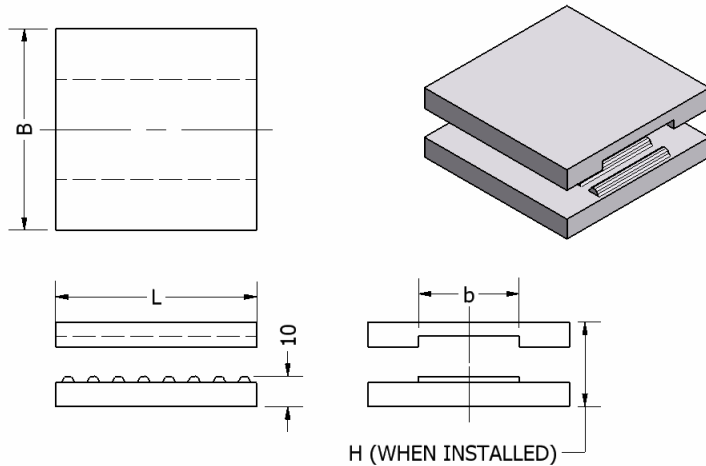

Part description:

B x L (belt pitch) Type A-1  
clamp assembly

Note:

Standard material is AL 6061

H = overall thickness including belt

See Appendix for installation notes

Clamp Assembly Type A-1					
Belt Pitch	Belt Width b(mm)	Part Description	B(mm)	L(mm)	H(mm)
T5	25	50x80 T5 A-1 clamp assembly	50	80	18.5
	32	60x80 T5 A-1 clamp assembly	60		
	50	75x80 T5 A-1 clamp assembly	75		
T10	25	50x80 T10 A-1 clamp assembly	50	80	19.5
	32	60x80 T10 A-1 clamp assembly	60		
	50	75x80 T10 A-1 clamp assembly	75		
AT5	25	50x80 AT5 A-1 clamp assembly	50	80	19.0
	32	60x80 AT5 A-1 clamp assembly	60		
	50	75x80 AT5 A-1 clamp assembly	75		
AT10	25	50x80 AT10 A-1 clamp assembly	50	80	19.5
	32	60x80 AT10 A-1 clamp assembly	60		
	50	75x80 AT10 A-1 clamp assembly	75		
ATL5	25	50x80 ATL5 A-1 clamp assembly	50	80	19.0
	32	60x80 ATL5 A-1 clamp assembly	60		
	50	75x80 ATL5 A-1 clamp assembly	75		
ATL10	25	50x80 ATL10 A-1 clamp assembly	50	80	19.5
	32	60x80 ATL10 A-1 clamp assembly	60		
BATK10	32	60x80 BATK10 A-1 clamp assembly	60	80	19.5
	50	75x80 BATK10 A-1 clamp assembly	75		



### Tensioning Clamp Type A-2

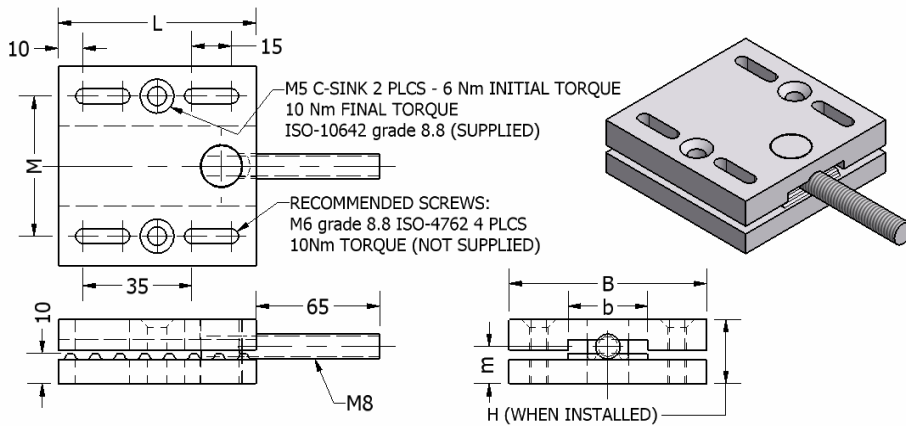

See Appendix for installation notes

Tensioner part description:

B x L (belt pitch) Type A-2 tension clamp

Notes:

- Standard material is AL 6061 with zinc-plated hardware
- H = overall thickness including belt
- Specify running direction for BAT and BATK pitches per appendix

Tensioning Clamp Type A-2							
Belt Pitch	Belt Width b(mm)	Part Description	B(mm)	L(mm)	M(mm)	m(mm)	H(mm)
T5	25	50x80 T5 Type A-2 tension clamp	50	80	38	10.25	18.5
	32	60x80 T5 Type A-2 tension clamp	60		46		
	50	75x80 T5 Type A-2 tension clamp	75		62		
T10	25	50x80 T10 Type A-2 tension clamp	50	80	38	11.25	19.5
	32	60x80 T10 Type A-2 tension clamp	60		46		
	50	75x80 T10 Type A-2 tension clamp	75		62		
AT5	25	50x80 AT5 Type A-2 tension clamp	50	80	38	10.75	19.0
	32	60x80 AT5 Type A-2 tension clamp	60		46		
	50	75x80 AT5 Type A-2 tension clamp	75		62		
AT10	25	50x80 AT10 Type A-2 tension clamp	50	80	38	11.25	19.5
	32	60x80 AT10 Type A-2 tension clamp	60		46		
	50	75x80 AT10 Type A-2 tension clamp	75		62		
ATL5	25	50x80 ATL5 Type A-2 tension clamp	50	80	38	10.75	19.0
	32	60x80 ATL5 Type A-2 tension clamp	60		46		
	50	75x80 ATL5 Type A-2 tension clamp	75		62		
ATL10	25	50x80 ATL10 Type A-2 tension clamp	50	80	38	11.00	19.5
	32	60x80 ATL10 Type A-2 tension clamp	60		46		
BATK10	32	60x80 BATK10 Type A-2 tension clamp	60	80	38	11.25	19.5
	50	75x80 BATK10 Type A-2 tension clamp	75		46		

## Tensioning Clamp Type A-3

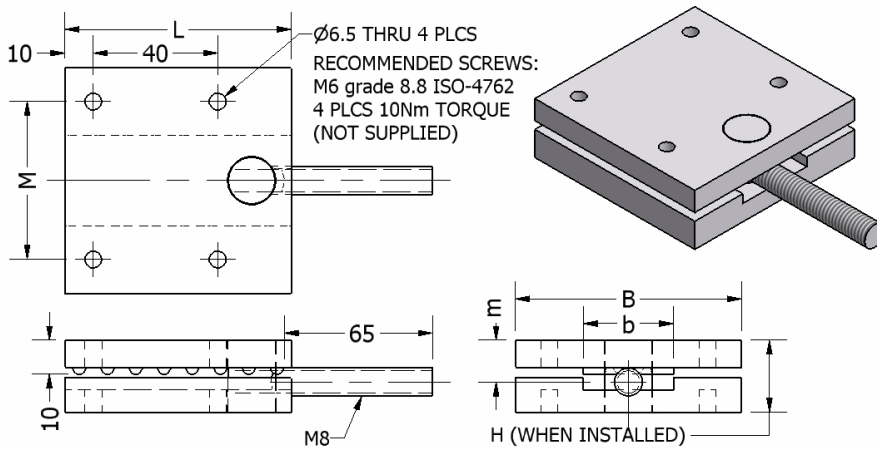

Tensioner part description:

B x L (belt pitch) Type A-3 tension clamp

Notes:

- Standard material is AL 6061 with zinc-plated hardware
- H = overall thickness including belt
- Specify running direction for BAT and BATK pitches per appendix

See Appendix for installation notes

Tensioning Clamp Type A-3							
Belt Pitch	Belt Width b(mm)	Part Description	B(mm)	L(mm)	M(mm)	m(mm)	H(mm)
T5	25	50x80 T5 Type A-3 tension clamp	50	80	38	10.25	18.5
	32	60x80 T5 Type A-3 tension clamp	60		46		
	50	75x80 T5 Type A-3 tension clamp	75		62		
T10	25	50x80 T10 Type A-3 tension clamp	50	80	38	11.25	19.5
	32	60x80 T10 Type A-3 tension clamp	60		46		
	50	75x80 T10 Type A-3 tension clamp	75		62		
AT5	25	50x80 AT5 Type A-3 tension clamp	50	80	38	10.75	19.0
	32	60x80 AT5 Type A-3 tension clamp	60		46		
	50	75x80 AT5 Type A-3 tension clamp	75		62		
AT10	25	50x80 AT10 Type A-3 tension clamp	50	80	38	11.25	19.5
	32	60x80 AT10 Type A-3 tension clamp	60		46		
	50	75x80 AT10 Type A-3 tension clamp	75		62		
ATL5	25	50x80 ATL5 Type A-3 tension clamp	50	80	38	10.75	19.0
	32	60x80 ATL5 Type A-3 tension clamp	60		46		
	50	75x80 ATL5 Type A-3 tension clamp	75		62		
ATL10	25	50x80 ATL10 Type A-3 tension clamp	50	80	38	11.00	19.5
	32	60x80 ATL10 Type A-3 tension clamp	60		46		
BATK10	32	60x80 BATK10 Type A-3 tension clamp	60	80	38	11.25	19.5
	50	75x80 BATK10 Type A-3 tension clamp	75		46		

## Tensioning Clamp Type B-1

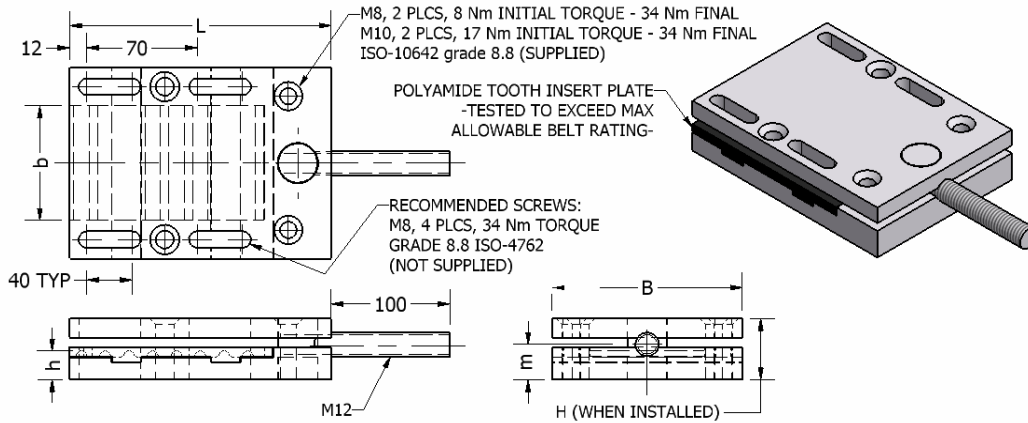

Tensioner part description:

B x L (belt pitch) Type B-1 tension clamp

Notes:

- Standard material is AL 6061 with zinc-plated hardware
- H = overall thickness including belt

See Appendix for installation notes

Tensioning Clamp Type B-1

Belt Pitch	Belt Width b(mm)	Part Description	B(mm)	L(mm)	M(mm)	m(mm)	h(mm)	H(mm)
T20	50	90x180 T20 Type B-1 tension clamp	90	180	70	20.5	19.08	32
AT20	50	90x180 AT20 Type B-1 tension clamp	90	180	70	20.5	19.08	32
ATL10	50	90x180 ATL10 Type B-1 tension clamp	90	180	70	20.5	19.80	32
ATL20	50	90x180 ATL20 Type B-1 tension clamp	90	180	70	20.5	18.68	32
BATK15	50	90x180 BATK15 Type B-1 tension clamp	90	180	70	20.5	19.58	32
ATS15	50	90x180 ATS15 Type B-1 tension clamp	90	180	70	20.5	19.38	32

## Tensioning Clamp Type B-2

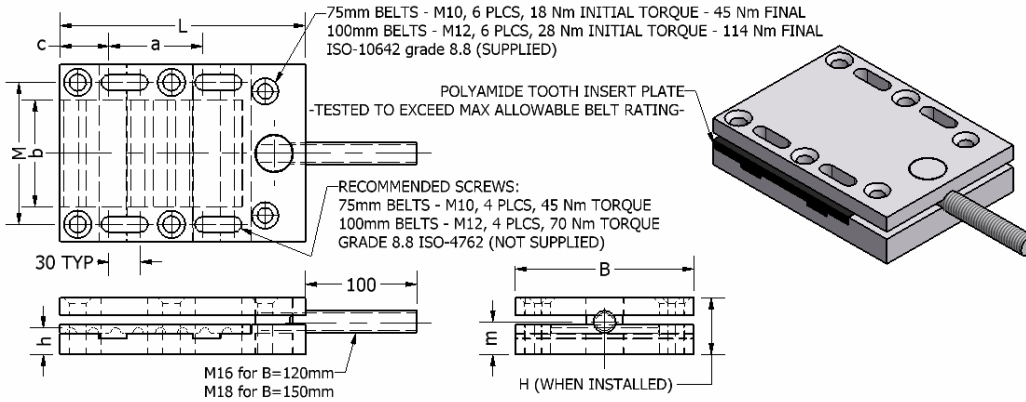

Tensioner part description:

B x L (belt pitch) Type B-2 tension clamp

Notes:

- Standard material is AL 6061 tooth plate, uncoated steel top plate and zinc-plated hardware
- steel coatings optional
- H = overall thickness including belt
- Specify running direction for BAT and BATK pitches per appendix

See Appendix for installation notes

### Tensioning Clamp Type B-2

Belt Pitch	Belt Width b(mm)	Part Description	B (mm)	L (mm)	M (mm)	m (mm)	a (mm)	c (mm)	h (mm)	H (mm)
T20	75	120x180 T20 Type B-2 tension clamp	120	180	97	19.5	65	29.5	18.08	33
	100	150x200 T20 Type B-2 tension clamp	150	200	124	25.5	72	35	24.08	42
AT10	75	120x180 AT10 Type B-2 tension clamp	120	180	97	19.5	65	29.5	19.09	33
	100	150x200 AT10 Type B-2 tension clamp	150	200	124	25.5	72	35.0	25.09	42
AT20	75	120x180 AT20 Type B-2 tension clamp	120	180	97	19.5	65	29.5	18.08	33
	100	150x200 AT20 Type B-2 tension clamp	150	200	124	25.5	72	35	24.08	42
ATL10	75	120x180 ATL10 Type B-2 tension clamp	120	180	97	19.5	65	29.5	18.8	33
	100	150x200 ATL10 Type B-2 tension clamp	150	200	124	25.5	72	35	24.8	42
ATL20	75	120x180 ATL20 Type B-2 tension clamp	120	180	97	19.5	65	29.5	17.68	33
	100	150x200 ATL20 Type B-2 tension clamp	150	200	124	25.5	72	35	23.68	42
BATK10	75	120x180 BATK10 Type B-2 tension clamp	120	180	97	19.5	65	29.5	19.09	33
	100	150x200 BATK10 Type B-2 tension clamp	150	200	124	25.5	72	35	25.09	42
BATK15	75	120x180 BATK15 Type B-2 tension clamp	120	180	97	19.5	65	29.5	18.58	33
	100	150x200 BATK15 Type B-2 tension clamp	150	200	124	25.5	72	35	24.58	42
ATS15	75	120x180 ATS15 Type B-2 tension clamp	120	180	97	19.5	65	29.5	18.38	33
	100	150x200 ATS15 Type B-2 tension clamp	150	200	124	25.5	72	35	24.38	42

## Tensioning Clamp Type C

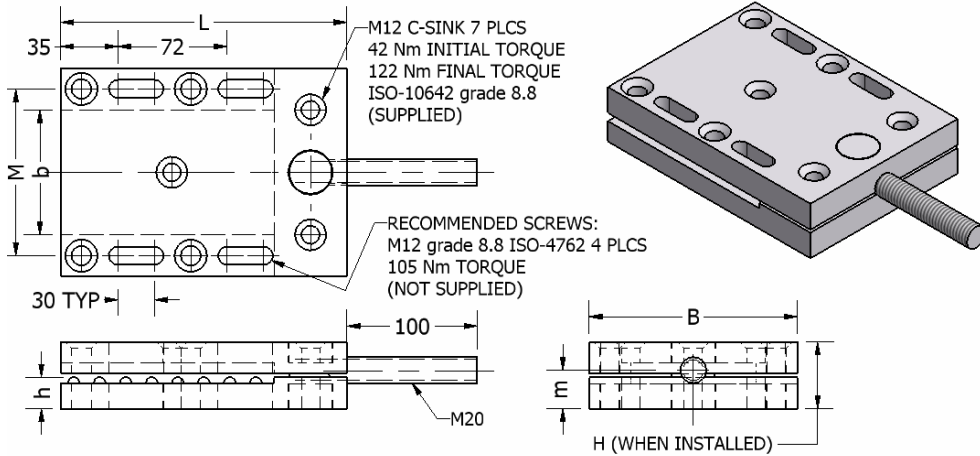

Tensioner part description:

B x L (belt pitch) Type C tension clamp

Notes:

- Standard material is uncoated steel with zinc-plated hardware
- Steel coatings optional
- H = overall thickness including belt

See Appendix for installation notes

Tensioning Clamp Type C

Belt Pitch	Belt Width b(mm)	Part Description	B(mm)	L(mm)	M(mm)	m(mm)	h(mm)	H(mm)
T20	150	200x210 T20 Type C tension clamp	200	210	174	25.5	24.08	42
AT10	150	200x210 AT10 Type C tension clamp	200	210	174	25.5	25.09	42
ATS15	150	200x210 ATS15 Type C tension clamp	200	210	174	25.5	24.38	42
AT20	150	200x210 AT20 Type C tension clamp	200	210	174	25.5	24.08	42

## Custom Clamps

Custom Clamps machined to print are available in various materials and surface finishes. Custom clamps modified from stock AL 6061 extruded clamps are available in as little as 8 days. Submit drawings or technical specifications to [Applications Engineering](#) for quotations.

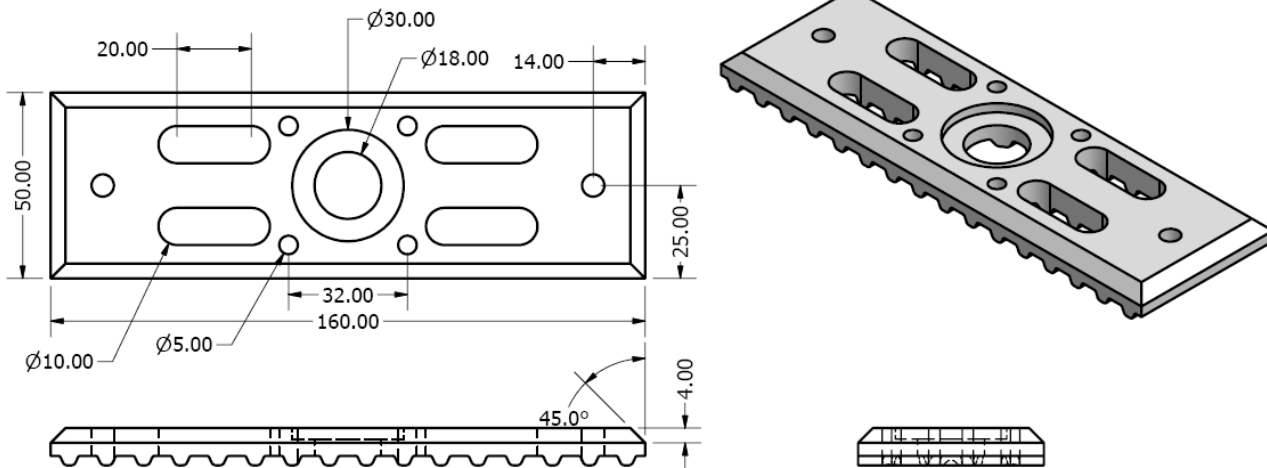

## Appendix: Tensioning Clamp Installation Notes

Place at least 5 belt teeth into the clamp to achieve maximum strength. Bolt the clamp plates together sandwiching the belt. Refer to tensioner diagram for recommended initial tightening torque for the countersunk screws. Place the threaded tensioning rod through a hole on a mounted fixture. By tightening a nut on the threaded rod the tensioning clamp will pull the belt and apply tension. Refer to catalog B207 pg. 5 or the online calculator for recommended pretension. After applying the proper tension, install and tighten the 4 mounting bolts in their slotted adjustment holes to keep the clamp in position. Refer to tensioner diagram for recommended tightening torque for the cap screws and final torque for any countersunk screws. By doing this, the pressure will be relieved on the threaded rod. Properly mounted tensioning clamps transfer all of the forces onto the mounted bolts and do not rely on the threaded rod. [Click to view video animation](#)

## Appendix: BAT and BATK Orientation

Running direction must be specified for BAT and BATK pitches as follows:

